

Transient Voltage
Surge Suppressors By:
Cratus Canada Ltd.
Info@cratuscanada.com

AC Distribution Panel Unit

Model # S8070A11S1



PowerEmt

“World Leader in Home Suppression”
Info@PowerEMT.com

The SineTamer[®] S80 series of units blends outstanding high-energy “impulse” suppression with excellent “ring-wave” transient protection with our Frequency Attenuation Network[®]. This durable device is intended for general purpose and sensitive/critical load applications. The S80 is typically installed at residential and small service entrances up to 600 amps. Compact size and non-metallic enclosure design also allow it to be installed directly inside electrical panels and individual equipment disconnects. The internal installation provides the absolute shortest possible lead length and optimum performance.

This economical device has features that are not available in devices costing many times its price. Its compact size makes installation a breeze. Maintenance Free operation and 15 Year Unlimited Free Replacement Warranty provide peace of mind.

GENERAL

Description:	Parallel connected, transient voltage surge suppressor device utilizing both high-energy handling and sine-wave tracking circuitry for virtual elimination of impulse and ring wave type transients. (actively tracking the AC sine wave)
Application:	Designed for use at ANSI/IEEE Categories C, B and A with susceptibility up to medium exposure levels. Designed to protect sensitive/critical loads fed from distribution panels, branch panels and/or individual equipment panels.
Warranty:	15 Years Unlimited Free Replacement
Product Qualifications:	Listed to ANSI/UL 1449 Fourth Edition by UL. ML record: E363345; CSA file: 259700, UL1283*, CE Compliant, (* Type 2 SPDs only) ISO 9001:2008, ANSI C62.72-2007, IEC 61643-1 Class 2&3

MECHANICAL

Enclosure:	High strength ABS Plastic, NEMA 1 (IP67) rated enclosure.
Mounting:	3/4” conduit fitting (internally threaded) and external mounting feet.
Connection Method:	#10 stranded wire.
Shipping Weight:	□ 6 lbs // 2.7 kg

ELECTRICAL

Circuit Design:	Parallel connected, internally fused, hybrid design incorporating all mode protection, and utilizing our encapsulated design to provide improved durability. All suppression circuits are encapsulated in our exclusive compound to assure long component life and complete protection from the environment and/or vibration.
Protection Modes: Response time:	L-N, L-L (Normal Mode), and L-G, N-G (Common Mode). (Five discrete modes) < 1 nanosecond.
Input Power Frequency:	50-60Hz constant
EMI/RFI Noise Attenuation:	30dB Max. from 1kHz to 10MHz
Capacitance:	Up to 3.5 uF Max.
Circuit Diagnostics:	Super Bright LED, 1 per phase, normally on.
Temperature Rating/RH	Up to 80°C. 0 – 99% Relative Humidity Non-Condensing
Fusing:	Component Level Thermal and Board Level Current Fusing
Energy Consumption:	8mA Total (Approximately 4mA per LED)
Nom. Discharge Current (In)	
KAIC Rating:	10 kA. 200 KAIC when installed according to installation instructions



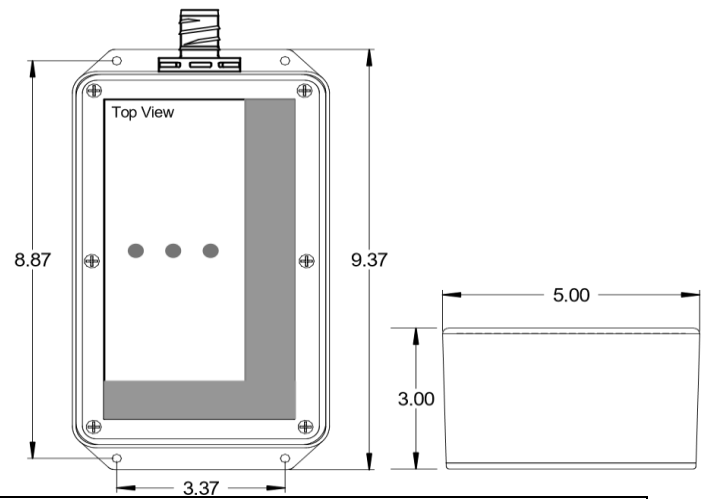

Because we are constantly seeking to improve our products, specifications are subject to change at any time. © 2017 ECS International Inc. Specification Last Changed 10/2016 S8070.doc

MEASURED LIMITING VOLTAGE PERFORMANCE AND ELECTRICAL SPECIFICATIONS

Model	Circuit Type	MCOV	Peak Surge Current (Amps) Per Mode/Phase	Mode	ANSI/IEEE C62.41 & C62.45 Let-Through Voltage Test Results		
					A1 2kV, 67A 100KHz Ring Wave 270° Phase Angle	Cat B3/C1 (6 kV, 3 kA) 90° Phase Angle	C3 20kV, 10kA Impulse Wave 90° Phase Angle
S8070A11S1	120/240V, Split Ø (3 wire + ground)	300 L-L 150 L-N 150 L-G 150 N-G	20,000 / 40,000	L-L L-N L-G N-G	55 45 55 50	720 445 469 600	1200 914 1200 1200

Let-Through Voltage Test Environment: Positive Polarity. Time base=1ms. All voltages are peak ($\pm 10\%$). Surge voltages are measured from the insertion point of surge on the sine wave to the peak of the surge. All tests are Dynamic (voltage applied) except N-G which is static (no voltage applied). All tests were performed with 6 inches of lead length outside the device enclosure which simulates actual "as installed" performance.

Single-pulse, surge current capacities of 200,000 amps or less are determined by single-unit testing of all components within each mode. Present industry test equipment limitations require testing of individual components or sub-assemblies within a mode for single-pulse, surge current capacities over 200,000 amps.



PowerEmit

Info@PowerEMT.com